

Micron MR603b Quick Start Guide

This guide is designed to get you started with MR603b as quickly as possible. More information can be found in the user manual - <http://micronrc.uk/mr603b>.

MR603 receiver is 2.4GHz DSM2/DSMX receiver, with 3A max brushed speed controller, for use in larger scale model rail locomotives and road vehicles. It is compatible with any Spektrum DSM2 or DSMX transmitter including all of the Micron [model rail transmitters](#). The voltage range is 5V to 20V.

If purchased with a transmitter, MR603b will be bound to the transmitter and is ready for use; otherwise, it requires binding to your transmitter. Once bound, the transmitter should be switched on before the MR603b. If the transmitter is not switched on, MR603b will automatically enter bind mode 10 seconds after switch on; it may also be configured to bind only manually using pads P5 and P6.

Usage

- Do not bend the receiver circuit board
- Connect the positive and negative input pads to a suitable battery or power supply, via a on/off switch in the positive lead. A resettable fuse **must** be placed in the battery positive lead to protect the battery in the event of a wiring or component fault.
- Connect the 'M' pads to your vehicle motor, removing any connections to track pickups. If your loco has suppression capacitors or chokes fitted, leave them in place. It is not usually necessary to fit suppression components if your loco do not already have them. Contact Micron if you do experience symptoms of motor noise interference.
- Connect any auxiliary circuits to the F and P pads; the 3.3V pads may be used for powering auxiliary circuits with a maximum of 20mA per pad. F pads are switches, open circuit when off and connected to negative when on.
- Protect the receiver board before applying power for testing. It must not be allowed to touch anything metal. If MR603b was purchased with the heatshink cover supplied loose, slide this over the circuit board.
- After switching on:
 - the CPU LED (at side of receiver board) will emit a rapid flash followed by a flash count corresponding to the selected configuration (default = 1), shown twice
 - the CPU LED will then slow flash while MR603b is searching for its bound transmitter; if not already bound, approx 10 seconds later the receiver will go into bind mode and the RF LED (near aerial on opposite of board to CPU LED) will show a rapid flash; switch your transmitter on in bind mode and the RF LED will show an irregular slow flash eventually lighting continuously.
- When bound:
 - the CPU LED will be on to show receipt of good data from the transmitter
 - the RF LED will be on and may flicker due to electrical (e.g motor) noise, signal fades caused by reflections, interference from WiFi or Bluetooth signals, or overloading from the transmitter (this will happen if the transmitter is too close)
 - the CPU LED will show a repeated double flash when deselected (transmitter Selecta switch is moved)
 - the CPU LED will show a repeated 5 flash if the low voltage cutoff has triggered
- After testing, apply the heatshrink cover if not already fitted.
- Fix the receiver in place and route the aerial so that the last 30mm can 'see' the transmitter for best range - e.g. by routing through a hole in the vehicle body. The aerial should not be cut short or made longer as this will affect operation. It is important to perform a range check after installation to ensure you have full control of your loco/vehicle at all positions around the layout. Double sided foam-cored sticky tape is ideal for mounting the receiver.

Connections

MR603b has solder pads for:

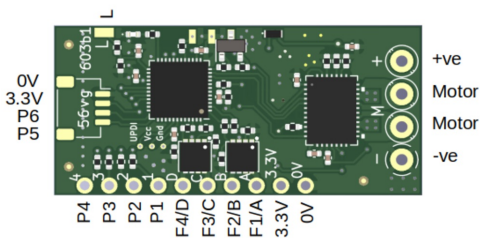

- power input (positive & negative battery)
- motor output
- 3.3V from the on-board regulator (max of 200mA)
- an additional battery negative connection (0V) - useful for wiring LEDs to P pads
- L: used to monitor battery voltage when a booster module is used, e.g. to raise a single LiPo cell to 12V.
- P1..P6: these are logic level outputs, 0V when off and 3.3V when on; they can be configured for on/off switching or to output a servo signal; P5 and P6 are at the opposite end of the board to the battery and motor pads, a 4 pin JST-SH socket may optional be fitted for P5, P6, 3.3V and 0V
- F1..F4: these are FET switches capable of up to 2A; they are open circuit when off and connected to battery negative when on; a load should be wired between the F pad and battery positive, or the 3.3V pad for low current loads; labelled A..D on the receiver board and numbered 7..10 for programming

The simplest use of MR603b requires connection to a battery (via an on/off switch and resettable fuse) and to your loco/vehicle motor.

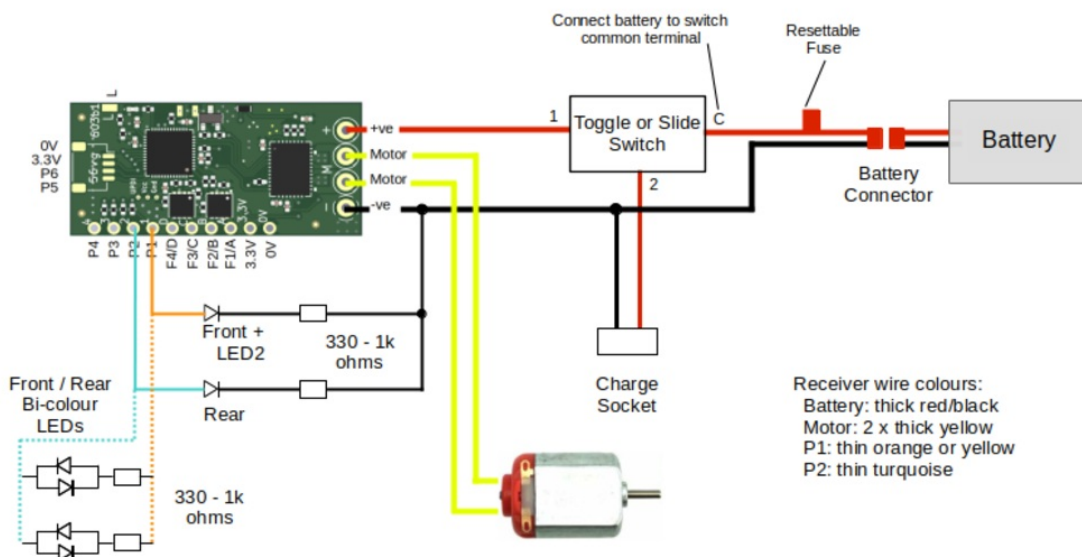

LEDs on P pads should be connected between the pad and battery negative (0V) with a series resistor appropriate to the required brightness.

Other connection diagrams (e.g. high current lights, sound card triggers) are available on the Micron MR603b web page.

Take care when soldering wires to P1..P4 and F1..F4 (A..D) as the pads are very close the radio sub-board. The recommended technique is to fill the pad hole with solder and then attach the wire to the top of the pad on the side opposite to the radio board - i.e. don't pass the wire through the pad hole.

Binding

To bind:

1. with transmitter off, switch the MR603 on
2. wait for the RF LED to flash fast
3. switch your transmitter on in bind mode
4. the RF LED will stop the rapid flash, flash a couple of times randomly and then light continuously
5. the MR603 is now bound to your transmitter